

order contacts separately

Cable description	Cable diameter	Wire gauge	P/N contact	P/N Crimping insert	P/N Crimping Tool	P/N Mounting tool
Elcurail/Rheyhalon MAZ CHXOE 4 x 0,75 mm <sup>2</sup> Nexans: 459 734 10	5,3mm	AWG 22-18	09 67 000 3476	0999 000 0648	0999 000 0647	0999 000 0639

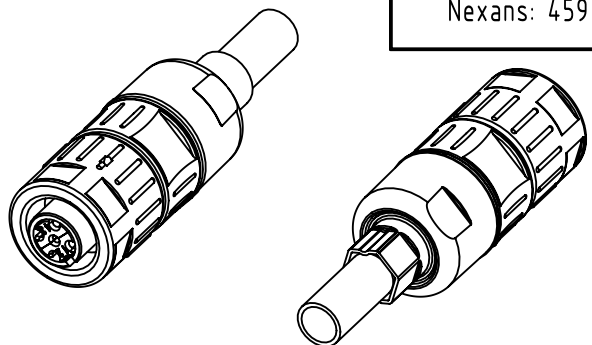

	All Dimensions in mm Original Size DIN A4	Scale 1:1	Free size tol.		Ref.
	All rights reserved Department EL PD	Created by 406403	Inspected by FARCASIU	Standardisation ROEBEN	Sub.
HARTING D-32339 Espelkamp	Title M12 SD A-cod 4/5-pol Crimp Flange female				Doc-Key / ECM-Nr. 100855392/UGD/000/E 500000250904
	Type TB	Number 21038212513		Rev. E	Page 1/1