

Installation

Mechanical Structure & Dimensions

1

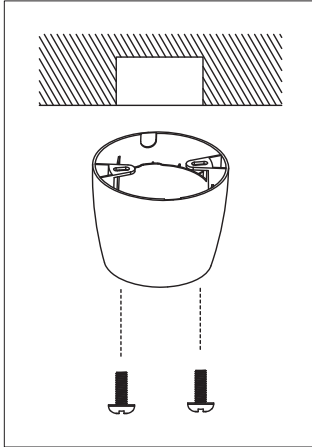

1. Fix the spring-mount box (with junction box)

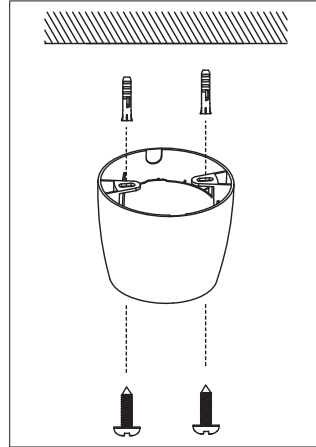

1. Fix the spring-mount box (without junction box)

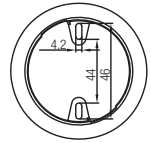

2

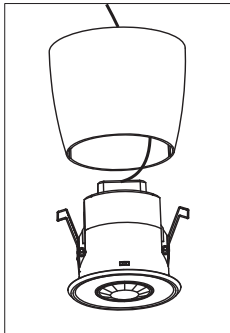

2. Fix cables

3

3. Install the sensor into the spring-mount box



4

Follow the track

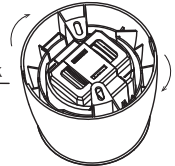

4. Rotate sensor counter-clockwise till the end to tighten up

5

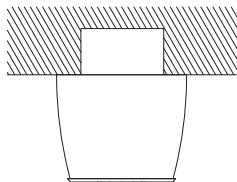

5. Finished (with junction box)

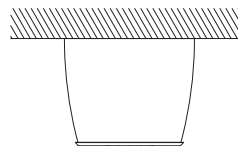

5. Finished (without junction box)