

SLC SmartOne ZB 24VDC 100W Mono



S32054

Important: Read All Instructions Prior to Installation

Function introduction

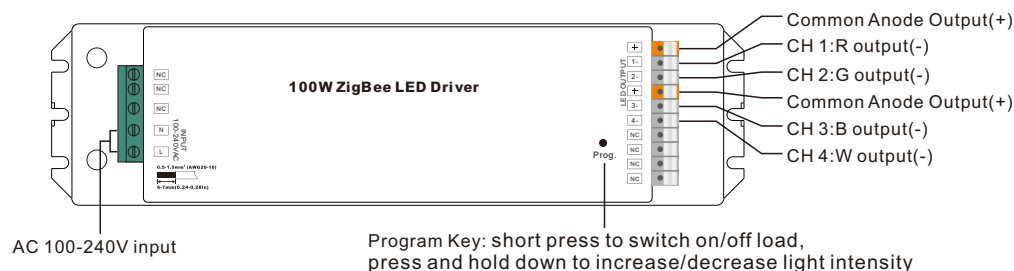

Note: 1) W channel can be turned on through Gateway's color temperature control interface which will mix RGB channels as 1 channel white and then make color tuning with the 4th channel white. Once turned on, the brightness of white channel will be controlled together with RGB channels.
 2) W channel can be controlled separately from RGB channels through RGBW zigbee remote or touch panel's W button, please refer to their manuals.

Product Data

Output	LED Channel	4
	DC Voltage	24V DC
	Max. Current	Max. 4.1A/ch, ch1+ch2+ch3+ch4=4.1A
	Voltage Tolerance	±1%
	Rated Power	max. 100W
Input	Voltage Range	100-240V AC
	Frequency Range	50/60Hz
	Power Factor (Typ.)	> 0.90 @ 230VAC
	Total Harmonic Distortion	THD ≤ 15% (@ full load / 230VAC)
	Efficiency (Typ.)	90% @ 230VAC full load
	AC Current (Typ.)	1.2A @ 100VAC, 0.5A @ 230VAC
	Inrush Current (Typ.)	Cold Start Max. 50A @ 230VAC
Control	Leakage Current	< 0.5mA /230VAC
	Dimming Interface	ZigBee
	Dimming Range	0.1%-100%
Protection	Dimming Method	Pulse Width Modulation
	Over Current	Yes, recovers automatically after fault condition is removed
	Over Temperature	Yes, recovers automatically after fault condition is removed

Environment	Working Temp.	-20°C ~ +45°C
	Max. Case Temp.	85°C (Ta="45°C")
	Working Humidity	10% ~ 95% RH non-condensing
	Storage Temp. & Humidity	-40°C ~ +80°C, 10% ~ 95% RH
Safety & EMC	Safety Standards	TUV EN61347-1, EN61347-2-13 approved
	Withstand Voltage	I/P-O/P: 3.75KVAC
	Isolation Resistance	I/P-O/P: 100M Ohms / 500VDC / 25°C / 70% RH
	EMC Emission	EN55015, EN61000-3-2, EN61000-3-3
	EMC Immunity	EN61547, EN61000-4-2,3,4,5,6,8,11, surge immunity Line-Line 1KV
Others	MTBF	187900H, MIL-HDBK-217F @ 230VAC at full load and 25°C ambient temperature
	Dimension	244*64*32mm (L*W*H)

- Dimmable LED driver with plastic case, 4 channels 24VDC constant voltage output
- Class 1 power supply, full isolated design
- Built-in two-stage active PFC function, PF > 0.90, Efficiency > 90%
- Compliant with Safety Extra Low Voltage standard
- Over load, over temperature protection
- ZigBee RGBW LED light device based on ZigBee 3.0 protocol, supports Touchlink commissioning
- Enables to control ON/OFF, light intensity and RGB color
- W channel can be controlled through Gateway's color temperature control interface
- W channel can be controlled separately from RGB channels through RGBW zigbee remote or touch panel's W button
- Can directly pair to a compatible ZigBee remote via Touchlink
- Supports zigbee green power and can bind max. 20 zigbee green power remotes
- Compatible with universal ZigBee coordinator or gateway products
- IP20 rating, suitable for indoor LED lighting applications
- 5 years warranty

Safety & Warnings

- DO NOT install with power applied to the device.
- DO NOT expose the device to moisture.

Wiring Diagram

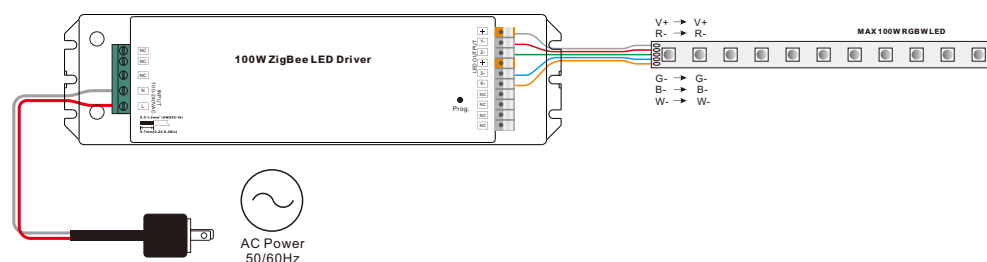

Operation

1. Do wiring according to connection diagram correctly.

2. This ZigBee device is a wireless receiver that communicates with a variety of ZigBee compatible systems. This receiver receives and is controlled by wireless radio signals from the compatible ZigBee system.

3. Zigbee Network Pairing through Coordinator or Hub (Added to a Zigbee Network)

Step 1: Remove the device from previous zigbee network if it has already been added to, otherwise pairing will fail. Please refer to the part "Factory Reset Manually".

Step 2: From your ZigBee Controller or hub interface, choose to add lighting device and enter Pairing mode as instructed by the controller.

Step 3: Re-power on the device to set it into network pairing mode (connected light flashes twice slowly), 15 seconds timeout, repeat the operation.

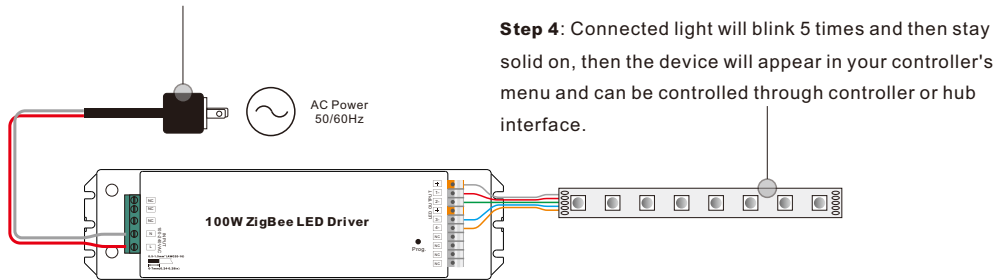

4. TouchLink to a Zigbee Remote

Step 1: Method 1: Short press "Prog" button (or re-power on the device) 4 times to start Touchlink commissioning immediately, 180S timeout, repeat the operation.

Method 2: Re-power on the device, Touchlink commissioning will start after 15S if it's not added to a zigbee network, 165S timeout. Or start immediately if it's already added to a network, 180S timeout. Once timeout, repeat the operation.

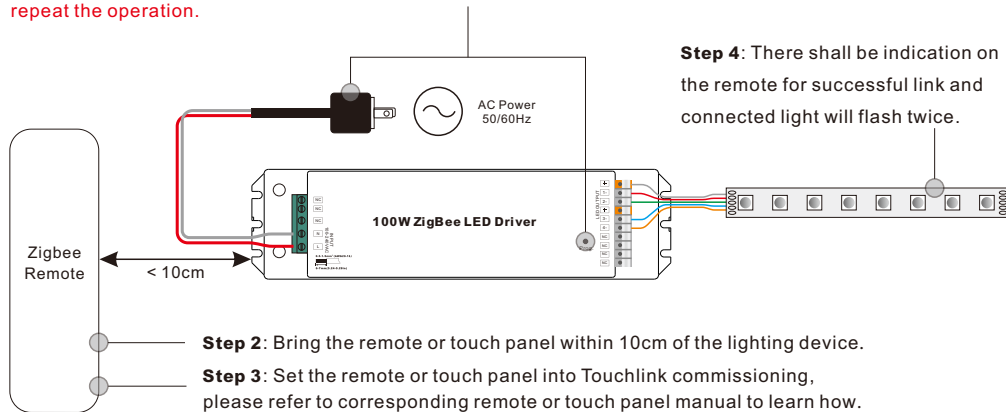

- Note:**
- 1) Directly TouchLink (both not added to a ZigBee network), each device can link with 1 remote.
 - 2) TouchLink after both added to a ZigBee network, each device can link with max. 30 remotes.
 - 3) For Hue Bridge & Amazon Echo Plus, add remote and device to network first then TouchLink.
 - 4) After TouchLink, the device can be controlled by the linked remotes.

5. Removed from a Zigbee Network through Coordinator or Hub Interface

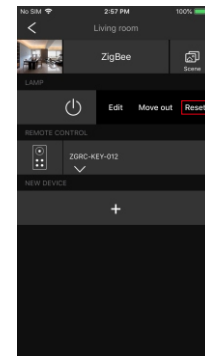

From your ZigBee controller or hub interface, choose to delete or reset the lighting device as instructed. The connected light blinks 3 times to indicate successful reset.

6. Factory Reset Manually

Step 1: Short press "Prog." key for 5 times continuously or re-power on the device for 5 times continuously if the "Prog." key is not accessible.

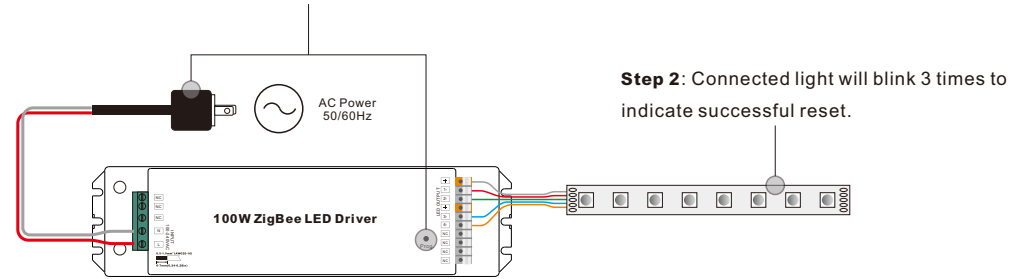

- Note:**
- 1) If the device is already at factory default setting, there is no indication when factory reset again.
 - 2) All configuration parameters will be reset after the device is reset or removed from the network.

7. Factory Reset through a Zigbee Remote (Touch Reset)

Note: Make sure the device already added to a network, the remote added to the same one or not added to any network.

Step 1: Re-power on the device to start TouchLink Commissioning, 180 seconds timeout, repeat the operation.

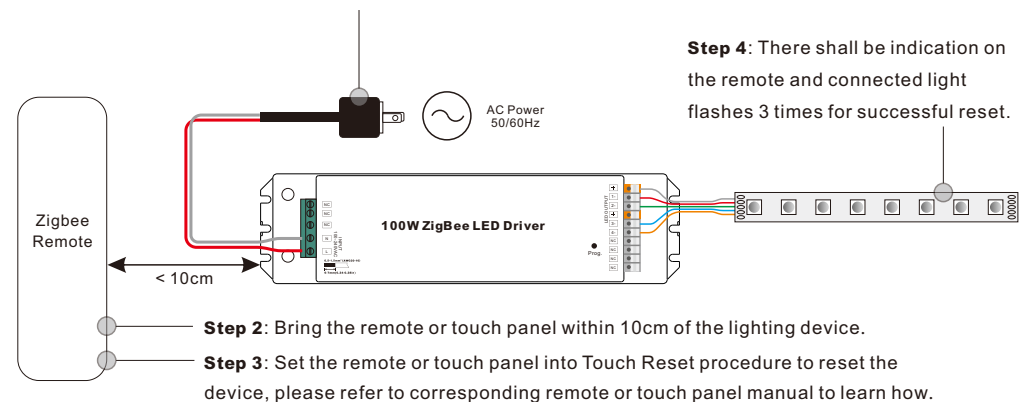

8. Find and Bind Mode

Step 1: Short press "Prog." button 3 times (Or re-power on the device (initiator node) 3 times) to start Find and Bind mode (connected light flashes slowly) to find and bind target node, 180 seconds timeout, repeat the operation.

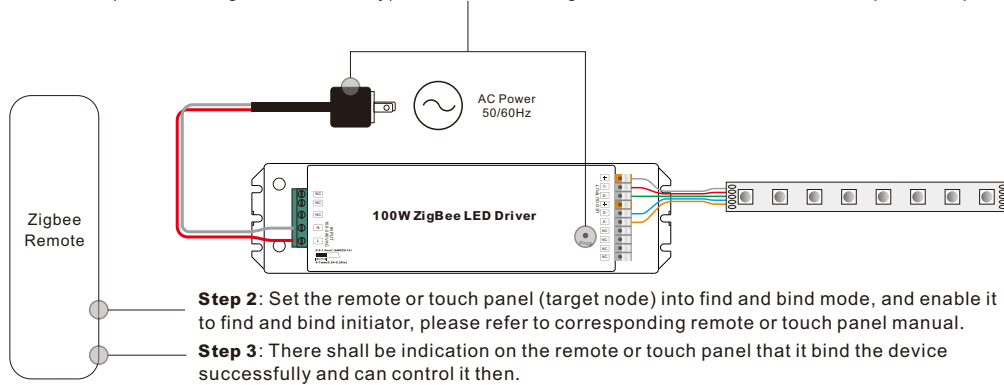

9. Learning to a Zigbee Green Power Remote

Step 1: Short press "Prog." button 4 times (Or re-power on the device 4 times) to start Learning mode (connected light flashes twice), 180 seconds timeout, repeat the operation.

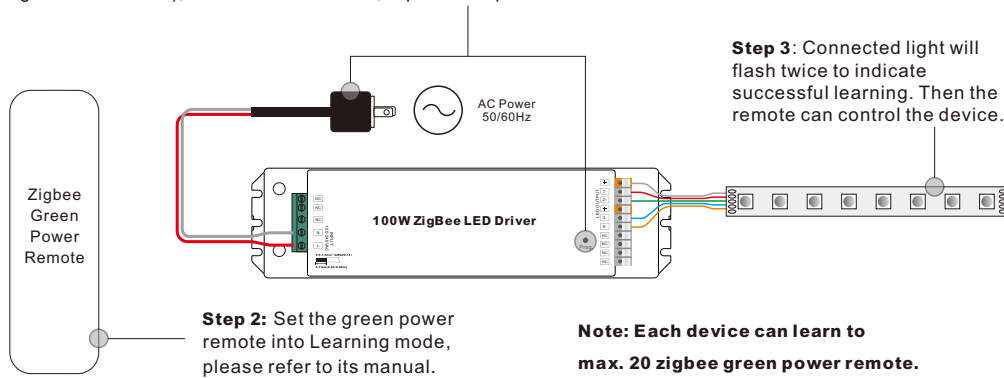

10. Delete Learning to a Zigbee Green Power Remote

Step 1: Short press "Prog." button 3 times (Or re-power on the device 3 times) to start delete Learning mode (connected light flashes slowly), 180 seconds timeout, repeat the operation.

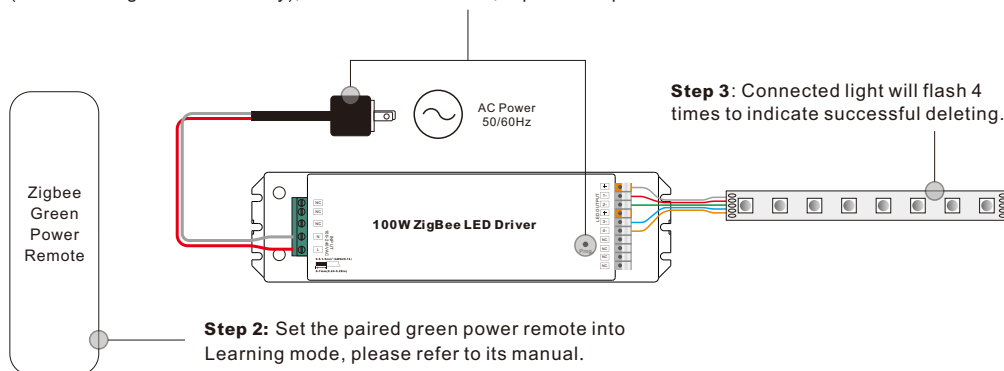

11. Setup a Zigbee Network & Add Other Devices to the Network (No Coordinator Required)

Step 1: Short press "Prog." button 4 times (Or re-power on the device 4 times) to enable the device to setup a zigbee network (connected light flashes twice) to discover and add other devices, 180 seconds timeout, repeat the operation.

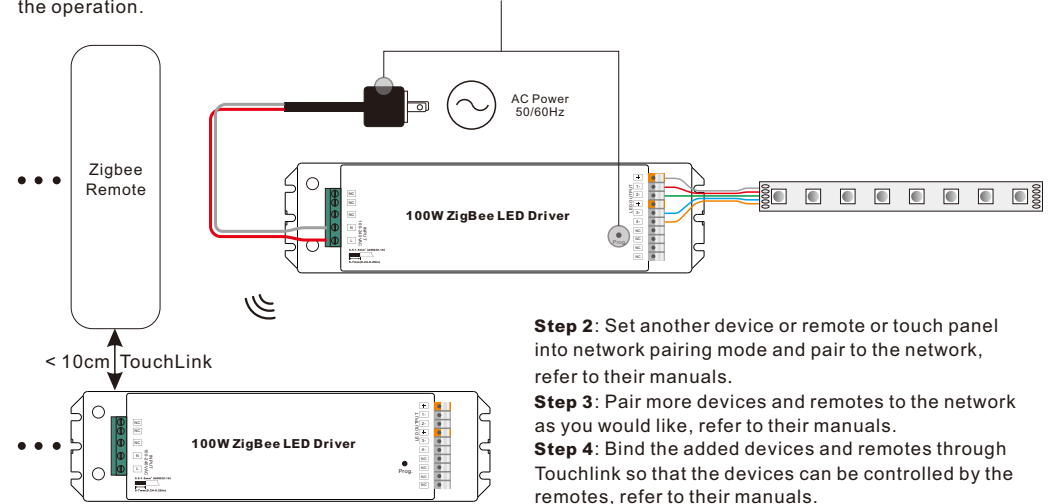

Note: 1) Each added device can link and be controlled by max. 30 added remotes.

2) Each added remote can link and control max. 30 added devices.

12. ZigBee Clusters the device supports are as follows:

Input Clusters

- 0x0000: Basic
- 0x0003: Identify
- 0x0004: Groups
- 0x0005: Scenes
- 0x0006: On/off
- 0x0008: Level Control
- 0x0300: Color Control
- 0x0b05: Diagnostics

Output Clusters

- 0x0019: OTA

13. OTA

The device supports firmware updating through OTA, and will acquire new firmware from zigbee controller or hub every 10 minutes automatically.

Product Dimension

