

Typ-Nr. S14572 S14585
 S14573 S14586
 S14574
 S14575

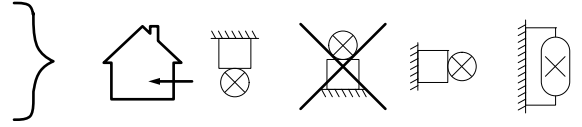

S12820
 S12821

IYON M 36W LED-TGR 3CV
 IYON M 36W LED-TGR LDO 3CY

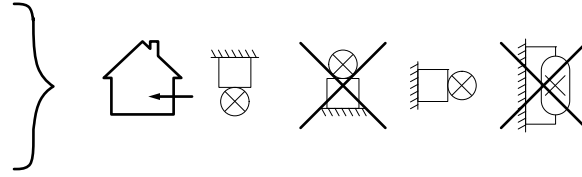

S14662
 S14663

IYON M T30 3CV
 IYON M T30 LDO 3CY

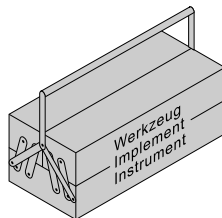
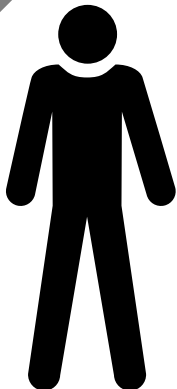
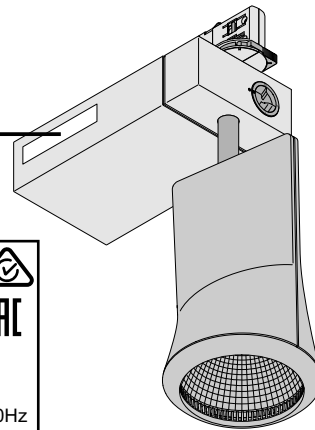
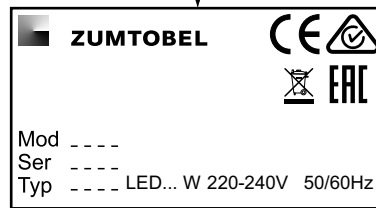
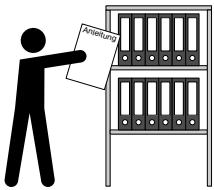
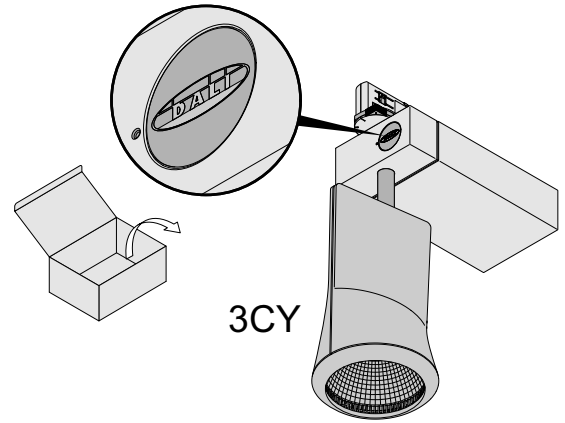
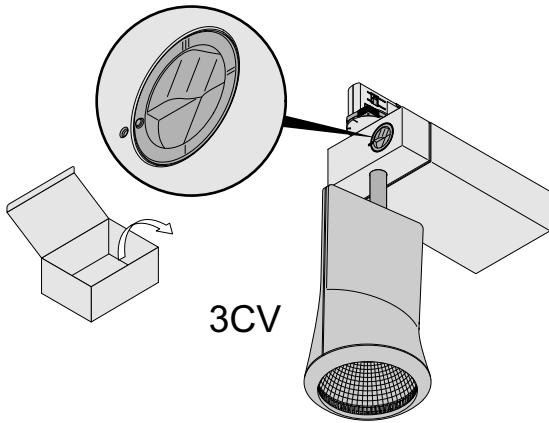

DE Die Montage und Inbetriebnahme darf nur von autorisiertem Fachpersonal durchgeführt werden.

NL De montage en inbedrijfstelling mogen enkel door erkend vakpersoneel worden uitgevoerd.

GB Installation and commissioning may only be carried out by authorized specialists.

NO/SE Monteringen och idrifttagandet får endast företas av auktoriserad fackpersonal.

FR L'installation et la mise en service doivent obligatoirement être effectuées par des techniciens.

FI Asennuksen ja käyttöönoton saa tehdä vain auktorisoitu ammattihenkilöstö.

IT Montaggio ed avviamento devono essere eseguiti solo da personale specializzato.

ES El montaje y la puesta en marcha sólo puede ser realizado por personal especializado autorizado.

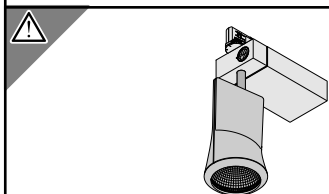
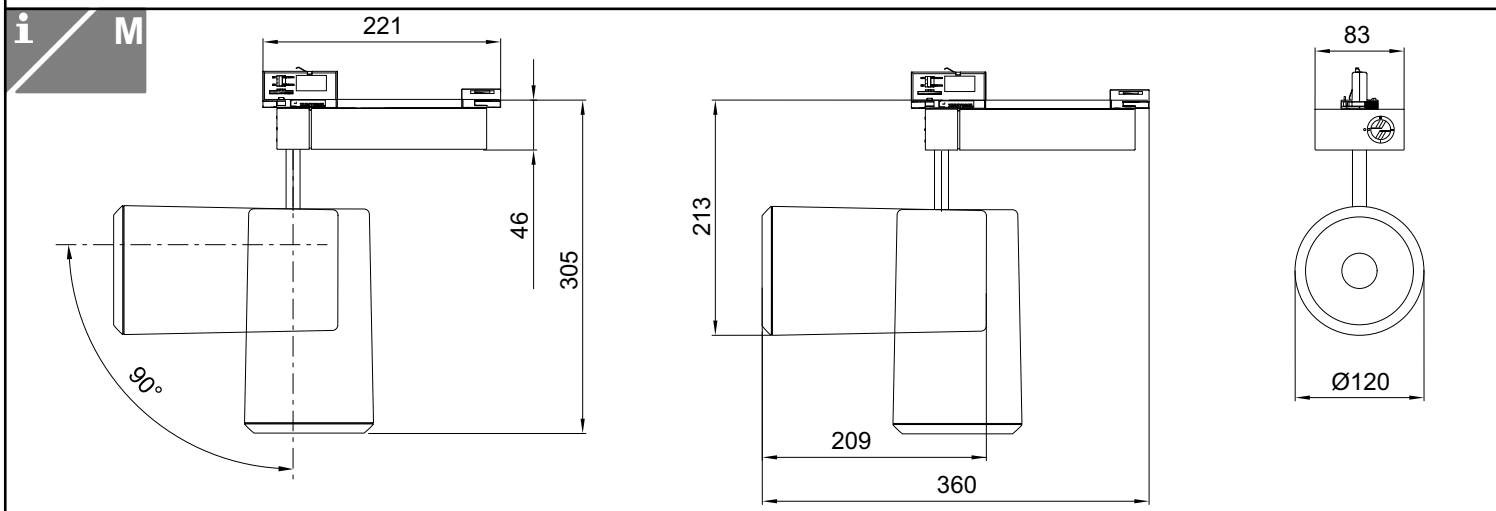
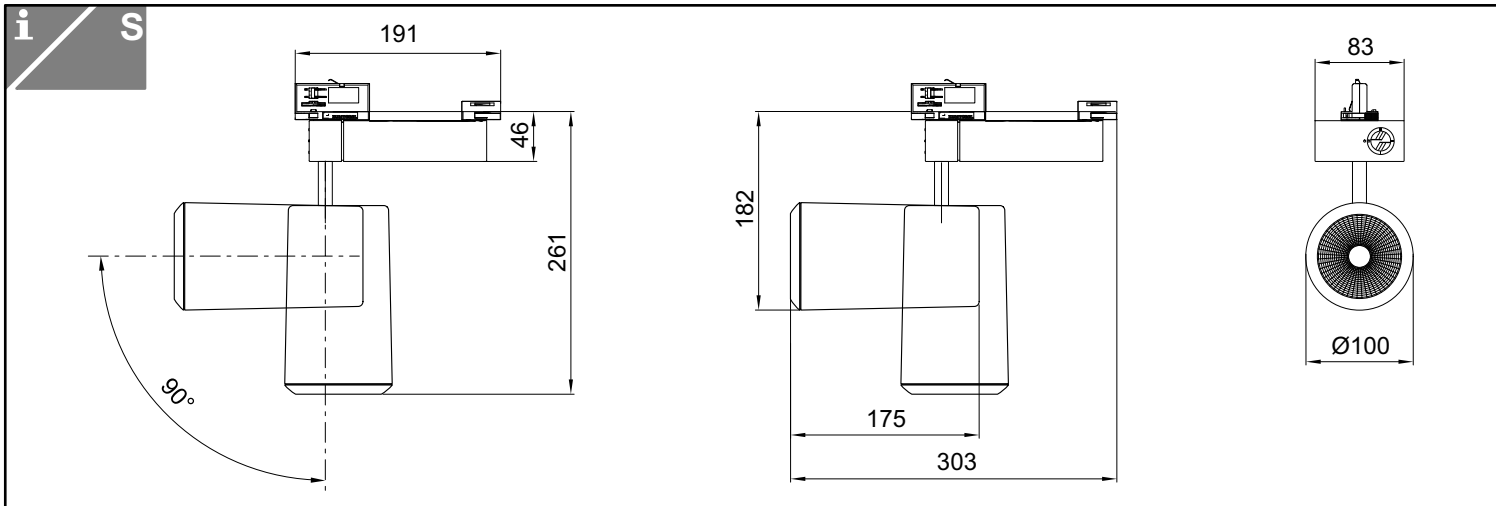

FR Le luminaire sert uniquement à l'éclairage et doit être installé conformément aux prescriptions nationales en matière d'installation. Toute autre utilisation ou installation est considérée comme "non conforme".

NO/SE Armaturen är uteslutande avsedd för belysning och ska installeras i enlighet med de nationella installationsbestämmelserna. All annan användning eller montering gäller som "icke ändamålsenlig".

DE Die Leuchte dient ausschließlich der Beleuchtung und ist entsprechend den nationalen Errichtungsbestimmungen zu installieren. Eine andere Nutzung oder ein anderer Einbau gilt als „nicht bestimmungsgemäß“.

IT L'apparecchio è destinato esclusivamente all'illuminazione e va installato in conformità alle leggi nazionali in vigore. Un altro impiego o un diverso tipo di montaggio non è considerato conforme alle disposizioni.

FI Valaisin on tarkoitettu ainoastaan valaistuskäyttöön, ja se on asennettava kansallisten määräysten mukaan. Muu käyttö tai muu asennus katsotaan sopimuksenvastaiseksi käytöksi.

GB The luminaire is used exclusively for lighting and is to be installed in accordance with the national installation regulations. Any other use or installation is regarded as "not according to instructions".

NL De lamp dient uitsluitend voor de verlichting en dient conform de nationale bouwbepalingen te worden geïnstalleerd. Een ander gebruik of een andere inbouw is niet conform.

ES La lámpara está destinada exclusivamente a la iluminación y debe ser instalada de acuerdo con las pertinentes normas nacionales. Cualquier otro uso o instalación no se considerará "previsto por la norma".



**gilt für:
Typ-Nr.**

**S12820
S12821**

- DE** Montage der Leuchte nur außerhalb des angegebenen Handbereichs (*) zulässig.
- GB** Luminaire may only be installed outside the reach area specified (*).
- FR** Montage du luminaire uniquement en dehors du volume d'accessibilité au toucher (*).
- IT** Montaggio degli apparecchi consentito solo al di fuori della portata di mano indicata (*).
- NL** Montage van de armatuur alleen buiten het opgegeven handbereik (*) toegelaten.
- NO/SE** Lampen skal monteres slik at det ikke er mulig å berøre den med hånden (*).
- FI** Valaisimen saa asentaa ainoastaan ilmoitetun käsittelyrajan (*) ulkopuolelle.
- ES** La luminaria debe montarse sólo fuera de la zona al alcance de la mano indicada (*).

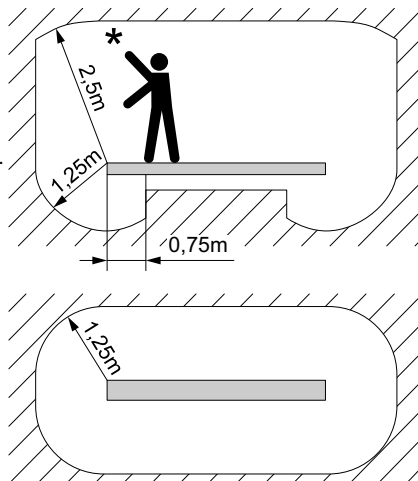

- DE** Grenze des Handbereichs (**)
- GB** Limit of arm's reach (**)
- FR** Limite du volume d'accessibilité au toucher (**)
- IT** Limite della portata di mano (**)
- NL** Grens van het handbereik (**)
- NO/SE** Grense for området man kan berøre med hånden (**)
- FI** Käsittelyraja (**)
- ES** Límite de la zona al alcance de la mano (**)

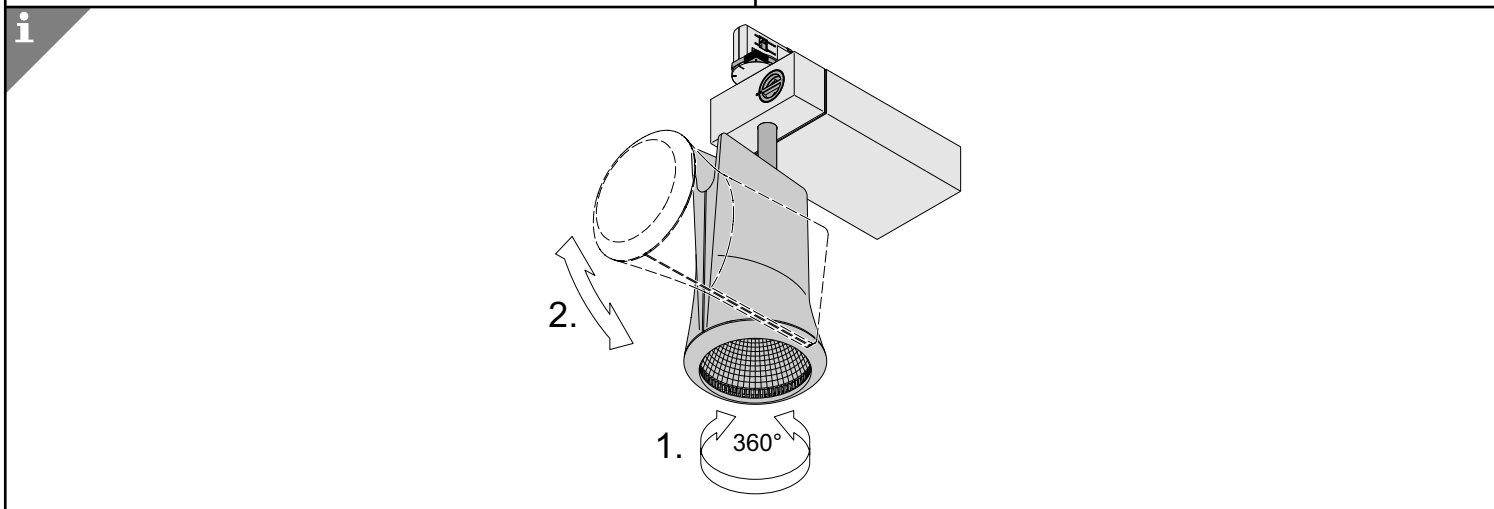
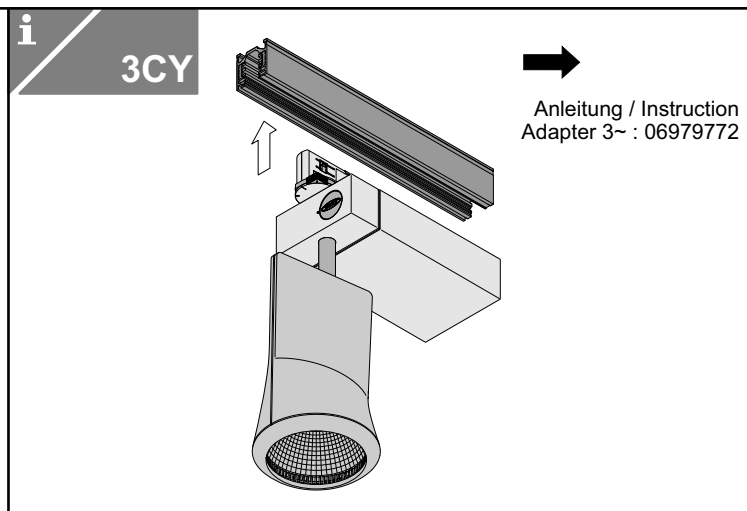
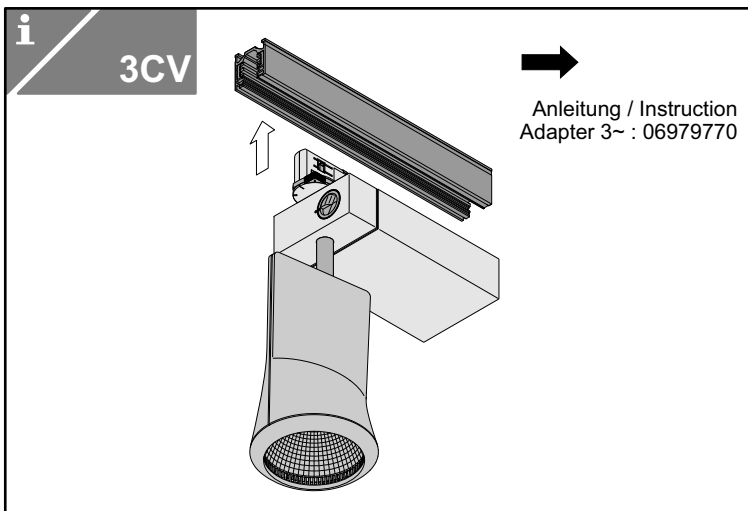

Zubehör - Accessory - Accessoire éventuel - Accessori
Toebehoren - Tillbehör - Lisätarvike - Accesorios

Ablendring

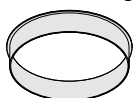

Ovalzeichner



Wabenraster



Reflektoren

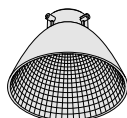

➔ Anleitung / Instruction
IYON ZUBEHOER : 06979612

Technische Änderungen vorbehalten. - Specifications subject to change without notice. - Modifications techniques sans préavis.
Modificazione tecnica senza preavviso. - Technische wijzigingen voorbehouden.
Med forbehold om tekniske endringer. - Oikeudet teknisiin muutoksiin pidätetään. - Modificaciones técnicas sin preaviso.