

Connector - INNOLINQ lead-free with QUICK-CONNECT and MULTI-GRIP



Product description	
BALS-Prd.-Nr	3118
EAN	4024941347297
product category (PG)	Connector INNOLINQ QC
current (A)	32A
number of poles (P99)	4p
number of poles (P)	3P+PE
position of earth contact (H)	6 h
voltage (V)	380 up to 415V

Product description	
frequency (HZ)	50 and 60Hz
protection degree (SA)	IP54
colour code 1 (KF1)	red RAL 3000
Colour of appliance	Hinged lid dark grey RAL 7012, Collar red RAL 3000, Cable gland dark grey RAL 7012, Housing cover dark grey RAL 7012
connection design (AT)	screwless spring terminals with KONTEX-ULTRA contact
maximum conductor size (LQ)	6,0 qmm
cable entry (KE)	Cable gland
Height	205mm
Width	80mm
Depth	99mm
material of enclosure (GM)	Polyamide
contact	The contacts are brass, The contact carrier is made of high temperature resistant material

Additional technical properties	
	This product is without any lead
	Multi-Grip cable gland with gasket and integrated strain relief, Screwless housing connection with snap fastening, For cable diameter from 13 up to max. 29 mm

Logistics data	
Weight/pcs	0.312 kg / Piece

Logistics data	
Packaging	Bag
Content amount	1 ST
EAN	4024941347297
Length	99 mm
Width	80 mm
Height	205 mm
Weight	0.313 kg
Volume	1,623.6 ccm

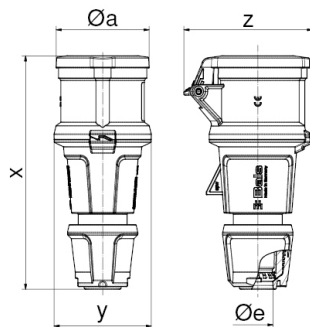

Ampere	16	16	32	32	32
Polzahl	3	5	3	4	5
$\text{Ø} a$	55,0	68,0	69,0	69,0	76,0
x	157,0	171,0	205,0	205,0	205,0
y	59,0	71,0	80,0	80,0	80,0
z	80,0	94,0	99,0	99,0	105,0
$\text{Ø} e$	18,0	21,0	29,0	29,0	29,0
Cond. mm ² min	1	1	2,5	2,5	2,5
Cond. mm ² max	2,5	2,5	6,0	6,0	6,0

