

MATRIC GX/RX | SYSTEM 40MM SUSPENDED

1. MONTAGE UND INSTALLATION | MOUNTING AND INSTALLATION:

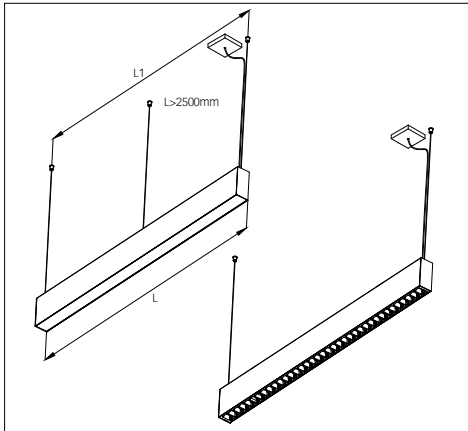

1. Bei allen Montagearbeiten Handschuhe tragen.
 Use gloves when handling the fixture.



L1[mm] = L[mm] - 40mm	
Opal / Microprismatic / Wallwasher	Lens Louver
L[mm]	L[mm]
890	930
1182	1194
1475	1458
1765	1723
2055	1987

2. Montageöffnungen.
 Installation openings.

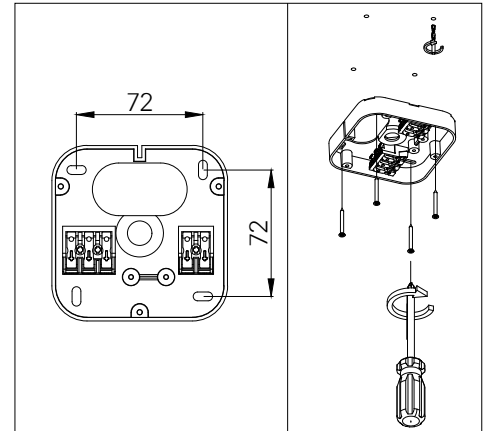

3.

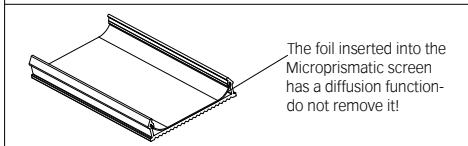
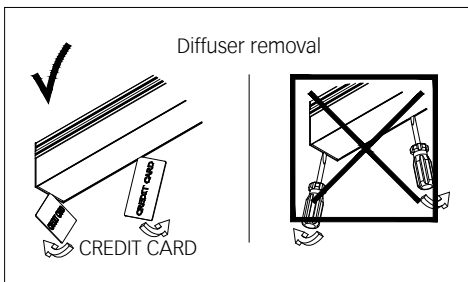

4.

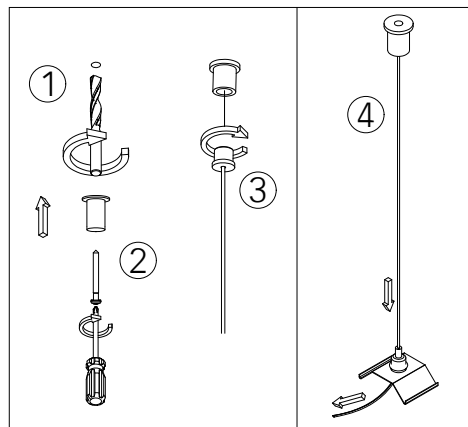

5.

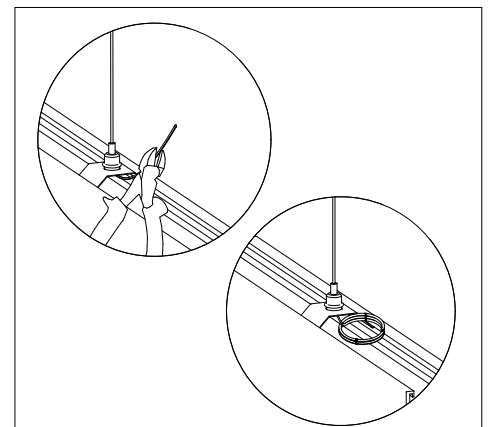

6. **IMPORTANT!**
 After levelling the luminaire at the desired height, cut off the excess of the suspension cord or roll it up and secure it to avoid a short-circuit caused by contact with the light sources.

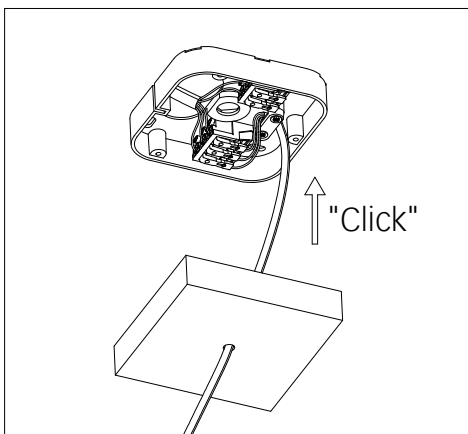

7.

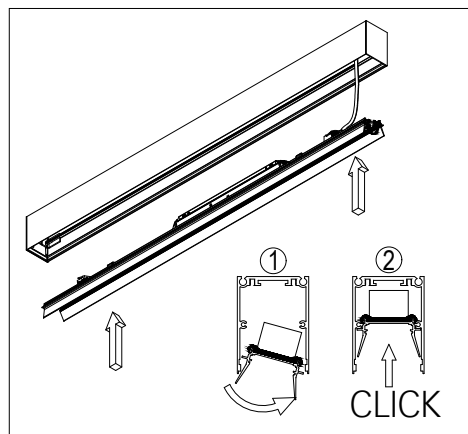

8.

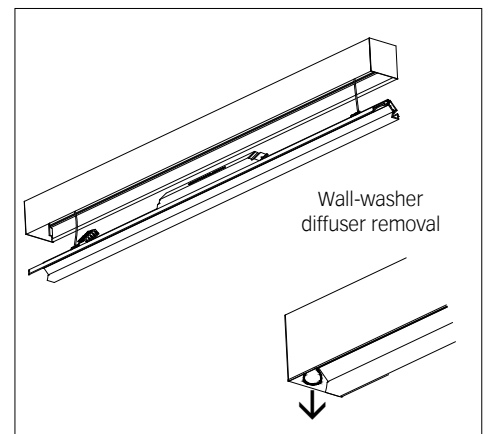

9.

MATRIC GX/RX | SYSTEM 40MM SUSPENDED

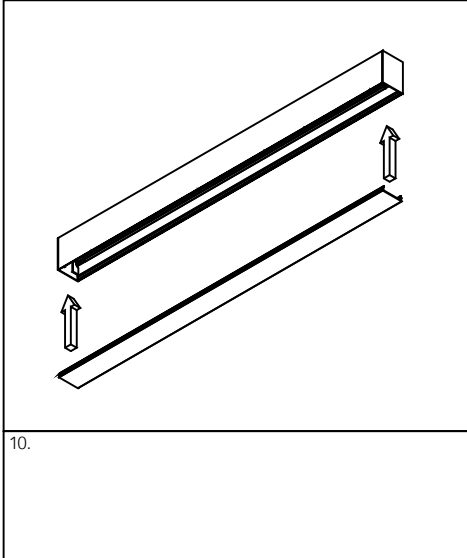

IMPORTANT:

- all sections must be suspended individually and perfectly levelled (horizontally and vertically) before connecting them together - this is crucial
- all suspension cords must be positioned perfectly vertical
- all suspension cords must be tensioned with the same strength
- if these conditions are not satisfied then the different parts will settle to different levels and work against one another.

11. Maximum current load allowed to through-wiring is 13A.
Non-user replaceable light source.