

A

B

C

D

assembly aid enclosed

A (2:1)

contact face acc. to IEC 61076-2-101

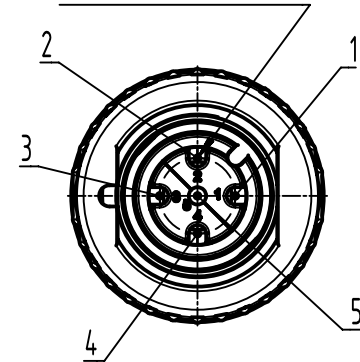
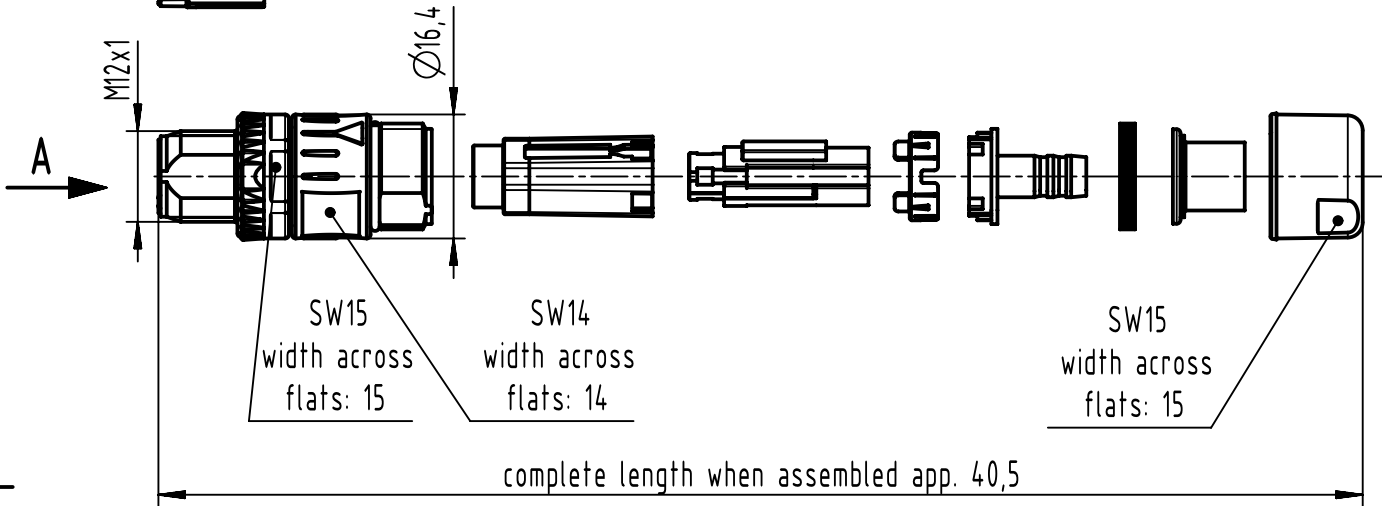

order contacts separately

Cable description	Cable diameter	Wire gauge	P/N contact	P/N Crimping insert	P/N Crimping Tool	P/N Mounting tool
BETAtrans GWK-ENX C-flex EN 50306-4 3P 300 V MM S 4x0,75mm <sup>2</sup> Leoni: 314713	5,8mm	AWG 22-18	09 67 000 3576	0999 000 0650	0999 000 0647	0999 000 0639

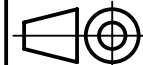
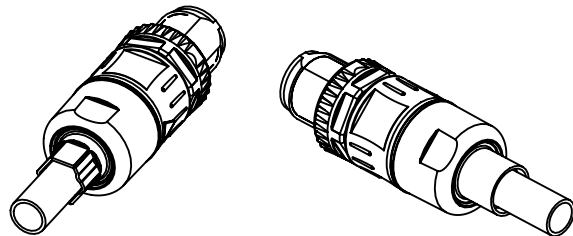

All Dimensions in mm  
Original Size DIN A4

Scale  
1:1

Free size tol.

Ref.

Sub.



All rights reserved

Department EL PD

Created by  
408279

Inspected by  
FARCASIU

Standardisation  
ROEBEN

Date  
2023-09-07

State  
Final Release

Title  
M12 SD A-cod 4/5-pol Crimp Flange male

Doc-Key / ECM-Nr.  
100932442/UGD/000/B  
500000252805

HARTING  
D-32339 Espelkamp

Type  
TB

Number  
21038211514

Rev. **B** Page  
1/1