

Printed board layout (1,6±0,2 thick)
view component side
(PCB plating = Tin)

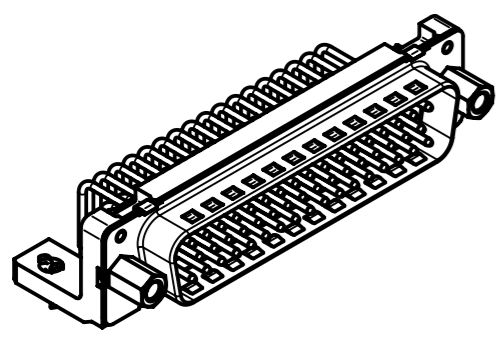
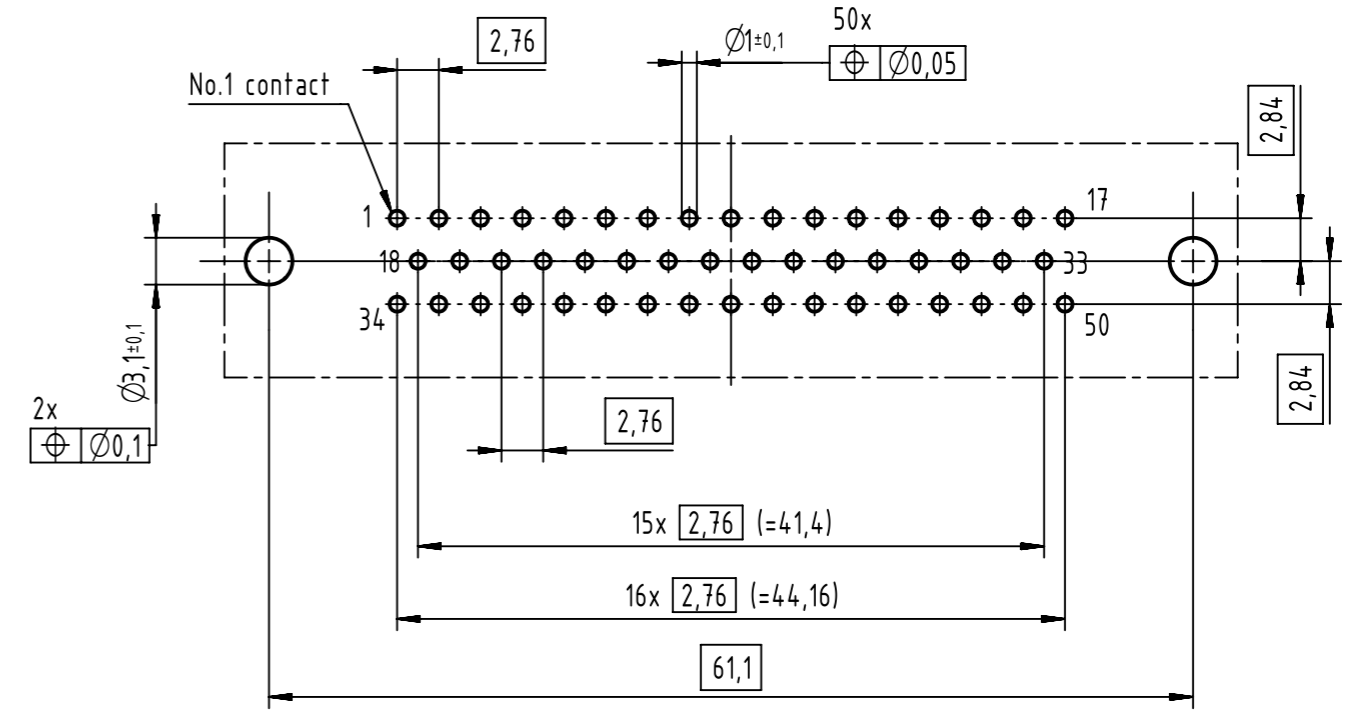

Mounting force on Printed board: 25-80 N

part number	performance level	nut thread
0966 563 7813	AU3	4-40 UNC
0966 563 6813	AU2	4-40 UNC
0966 563 5813	0,76µm AU	4-40 UNC

	All rights reserved Department EC PD - CN	Created by ZHUANGJ	Inspected by LUOK	Standardisation HOFFMANN	Date 2015-10-27	State Final Release	Ref. Sub.
	Title D-Sub STD 50-pole male 2,84mm pitch with screw lock Type TB Number 0966563X813						Doc-Key / ECM-Nr. 100644496/UGD/000/A 500000095926 Rev. A Page 1/1